

Specifications



1800374343

AMSM-1950

Open Deck Chiller

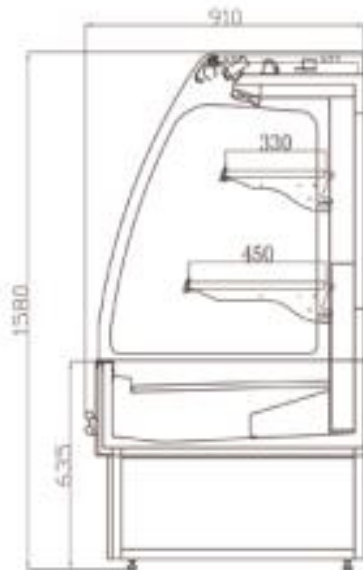

CABINET DIMENSIONS

	External
Height:	1580mm
Width:	1950mm
Depth:	910mm
Floor area:	1.77m ²



CABINET SPECIFICATIONS

Refrigeration system:	Electronic controlled, Ventilate Cooling
Refrigerant / Charge:	R404A
Nominal capacity:	1455 Watts
End Panel :	Hollow Side Panel
Cabinet temperature range:	3°C to +8°C
Condensate Water:	Stainless steel automatic evaporation
Electrical:	220-240 Volts a.c. 50 Hz
Power cord length:	2.5m
Internal lighting:	2 shelf with light
Bottom:	Stainless steel
Feet:	Wheel, front two brake
Insulation:	34mm polyurethane foam
Total weight:	160 kg

Austune Australia Pty Ltd reserve the right to alter specifications without notice.

Austune Australia Pty Ltd

Unit 3, 35 Davis Road Wetherill Park NSW 2164

Tel: 02 9725 1578